



# XEPA-0523-EXRS-ET.0

English	Technical data
01 Power	9.5 kW   32414 BTU/h
02 Frequency	60 Hz
03 Electric nominal heat input	5.35 kW   18254 BTU/h
04 Microwave circuit power	3.4 kW   11601 BTU/h
05 Microwave power output	2.16 kW   7370 BTU/h
06 Power supply cable type	H07RN-F
07 Voltage Power cable section Circuit breaker	<b>380-415V ~3PH+N+PE</b> 5G x 2,5 mm <sup>2</sup> 16 A I1 13 A I2 15.5 A I3 15 A In 4.5 A
220-240V ~3PH+PE 4G x 2,5 mm <sup>2</sup> 25 A I1 17 A I2 21 A I3 14.5 A	
08 Cable   Plug   El. Conn. mode	✓   X   -
09 RCD / GFCI	F
11 Water pressure	150-600 kPa   22-87 psi
12 Water max. consumption (steam)	18 l/h @ 200 kPa   4.76 gal/h @ 29 psi
13 Cavity dimensions (w x d x h)	399 x 394 x 418 mm 15-11/16" x 15-1/2" x 16-7/16"
14 Max. food load	16.5 kg   36 lbs
15 Max. temperature	260 °C   500 °F
16 IP protection class	3
17 Data connection	Lan,Wifi 2,4 GHz,Wifi 5 GHz
18 Communication protocol	WPA - Personal,WPA 2 - Personal

Terms and conditions of installations - Observe all local specific standard and regulations for installation and operations.



Italiano
01 Potenza
02 Frequenza
03 Potenza termica nominale elettrica
04 Potenza circuito microonde
05 Potenza microonde in uscita
06 Tipo cavo alimentazione
07 Tensione Sezione cavi alimentazione Magnetotermico
08 Cavo   Spina   Modalità connessione elettrica
09 RCD / GFCI
11 Pressione acqua
12 Consumo max acqua (vapore)
13 Dimensioni camera cottura (l x p x h)
14 Max. peso pieno carico
15 Temperatura max.
16 Grado protezione IP
17 Data connection
18 Protocollo di comunicazione

Français
01 Puissance électrique
02 Fréquence
03 Puissance calorifique nominale électrique
04 Puissance du circuit micro-ondes
05 Puissance de sortie micro-ondes
06 Type de câble d'alimentation
07 Tension Section câbles d'alimentation Disjoncteur
08 Câble   Prise   Branchement électrique
09 RCD / GFCI
11 Pression de l'eau
12 Consommation max. d'eau (vapeur)
13 Dimension de la cavité (l x p x h)
14 Charge max. des aliments
15 Température max.
16 Niveau de protection IP
17 Data connection
18 Protocole de communication

Português
01 Potência
02 Frequência
03 Potência térmica nominal elétrica
04 Potência do circuito de microondas
05 Potência de saída de microondas
06 Tipo de cabo de alimentação
07 Tensão Seção de cabos de alimentação Disjuntor
08 Cabo   Plugue   Modo de Conexão Elétrica
09 RCD / GFCI
11 Pressão da água
12 Max. consumo de água (vapor)
13 Dimensão de cavidade (c x l x a)
14 Max. capacidade de alimento
15 Max. temperatura
16 Grau de proteção IP
17 Data connection
18 Protocolo de comunicação

Espanol
01 Potencia
02 Frecuencia
03 Potencia térmica nominal eléctrica
04 Potencia del circuito de microondas
05 Potencia de microondas
06 Tipo de cable de alimentación
07 Voltaje Sección del cable de alimentación Disyuntor
08 Cable   Enchufe   Modo de conexión eléctrica
09 RCD / GFCI
11 Presión del agua
12 Consumo máximo de agua (vapor)
13 Dimensión de la cavidad (w x d x h)
14 Carga máxima de alimentos
15 Temperatura máxima
16 Grado de protección IP

Deutsch
01 Elektrische Leistung
02 Frequenz
03 Elektrische Nennwärmeleistung
04 Leistung der Mikrowellenschaltung
05 Leistung der Mikrowelle
06 Stromkabel Typ
07 Spannung Stromkabel Teil Sicherung
08 Leitung   Stecker   Elektrischer Verbindungsmodus
09 RCD / GFCI
11 Wasserdruck
12 Maximaler Wasserverbrauch bei Dampfbetrieb
13 Abmessungen des Hohlraums (B x T x H)
14 Maximale Beladungskapazität
15 Maximale Temperatur
16 IP-Schutzart
17 Data connection
18 Kommunikations-Protokoll

Русский
01 Мощность
02 Частота
03 Номинальная электрическая потребляемая мощность
04 Мощность СВЧ цепи
05 Выходная мощность микроволн
06 Тип силового кабеля
07 Напряжение Сечение силового кабеля Токовый автомат
08 Кабель   Вилка   Вид электрического соединения
09 RCD / GFCI
11 Давление воды
12 Максимальное потребление воды (пар)
13 Габариты камеры (ш x г x в)
14 Максимальная загрузка
15 Максимальная температура
16 Класс защиты IP
17 Data connection
18 Протокол передачи данных

中文
01 功率
02 频率
03 电额定热输入
04 微波电路电源
05 微波功率输出
06 电源电缆类型
07 电压 电源电缆截面 断路器
08 电缆和插头   电气连接方式
09 RCD / GFCI
11 水压
12 最大水消耗 (蒸汽)
13 腔室尺寸 (宽 x 深 x 高)
14 最大食物负荷
15 最高温度
16 IP保护等级
17 Data connection
18 通讯协议

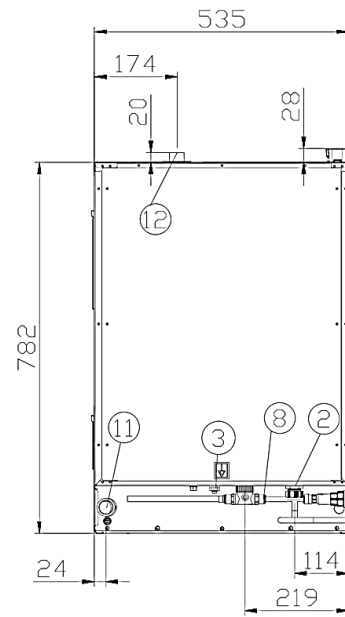
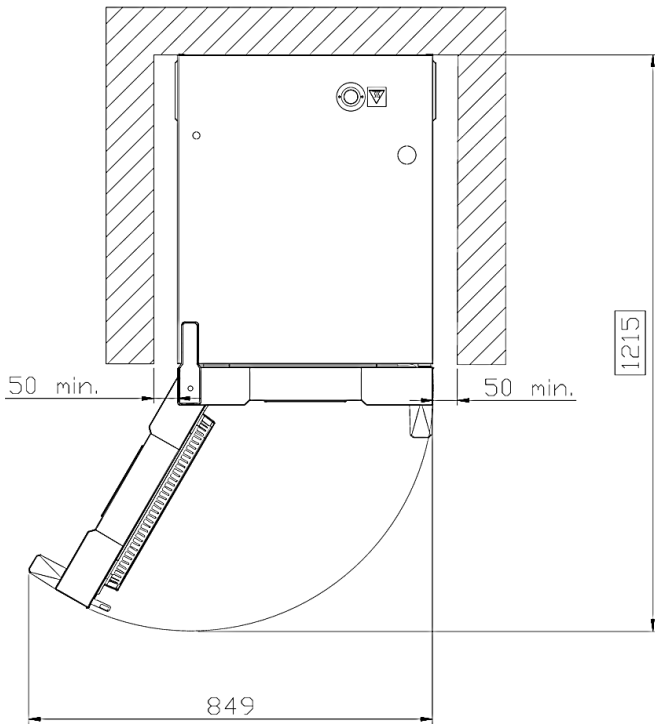
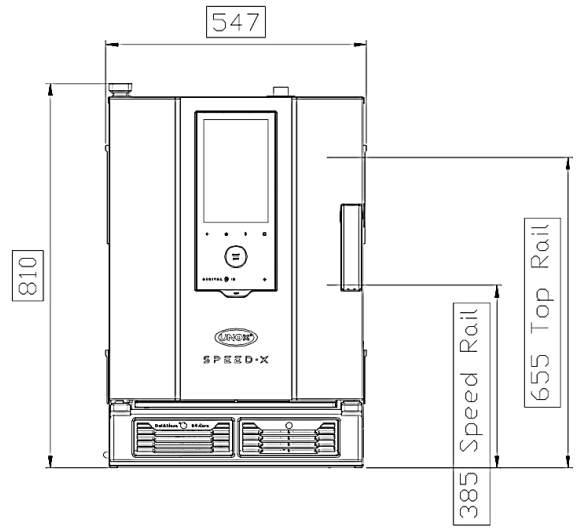
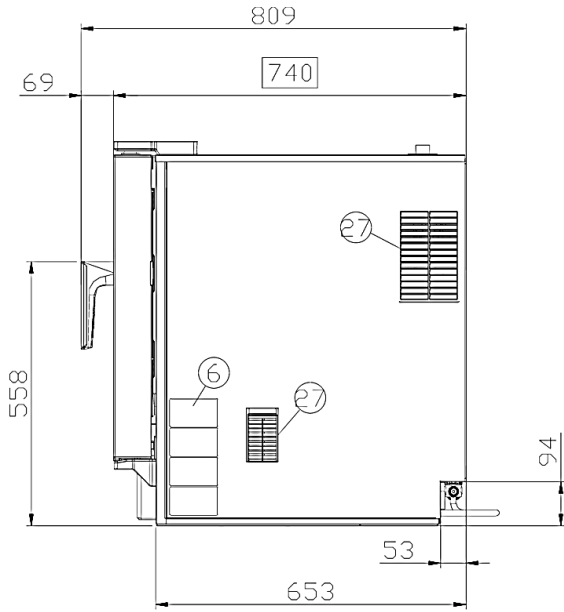



# XEPA-0523-EXRS-ET.0

	English	Italiano	Español	Français	Deutsch
02	Electrical connection	Allacciamento elettrico	Conexión eléctrica	Raccordement électrique	Elektrischer Anschluss
08	Water connection	Allacciamento idrico	Conexión de agua	Raccordement à l'eau	Wasseranschluss
09	Gas connection	Allacciamento gas	Conexión de gas	Raccordement au gaz	Gasanschluss
11	Water drain	Scarico acqua	Desagüe del agua	Evacuation	Abflussrohr
12	Smoke exhaust	Scarico fumi	Salida de humos	Aspiration des fumées	Abluftrohr
13	Accessories connection	Collegamento accessori	Conexión de accesorios	Connexion des accessoires	Anschluss des Zubehörs
30	Combustion fumes	Fumi di combustione	Gases de combustión	Fumées de combustion	Abgasse
31	Air inlet	Ingresso aria	Entrada de aire	Entrée d'air	Lufteinlass
	Русский	中文	Português		
02	Электрическое подключение	电源连接	Conexão elétrica		
08	Подключение к воде	水连接	Conexão hídrica		
09	Подключение к газу	燃气连接	Conexão gás		
11	Выход воды	排水	Saída de água		
12	Выход газов	排烟	Saída de fumaça		
13	Подключение аксессуаров	配件连接	Conexão de acessórios		
30	Продукты горения	燃烧烟雾	Fumaça de combustão		
31	Воздухозаборник	空气入口	Entrada de ar		

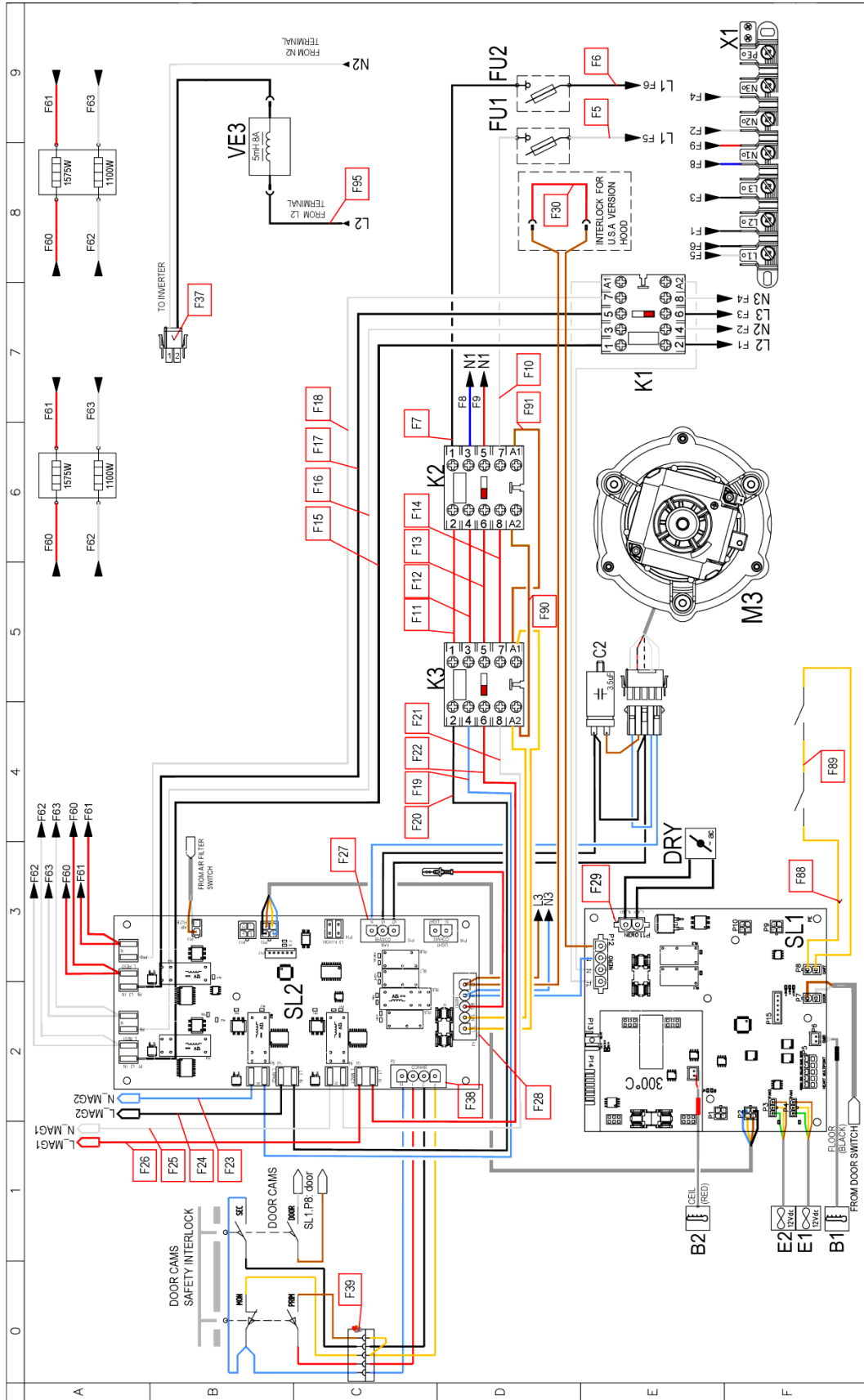

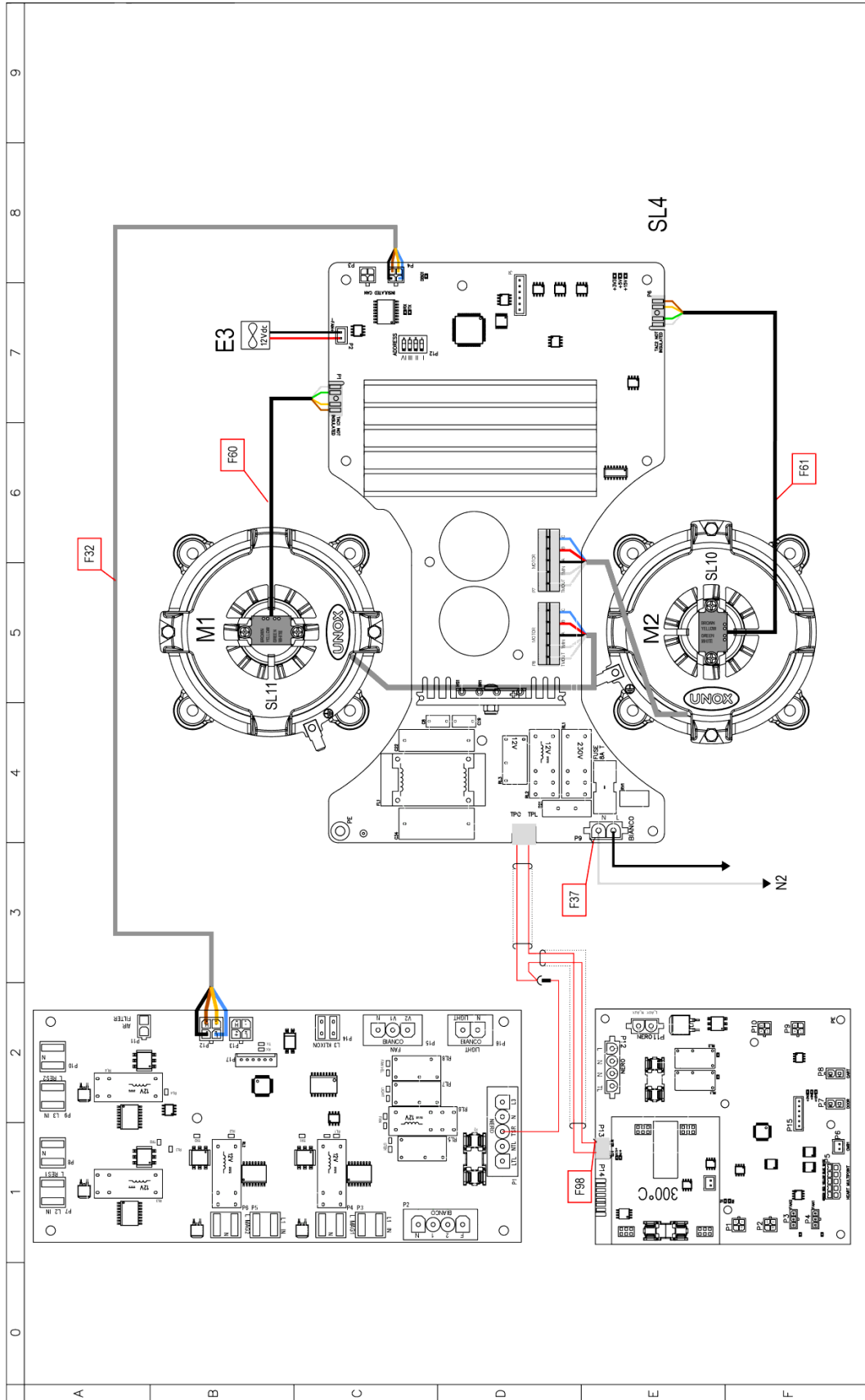

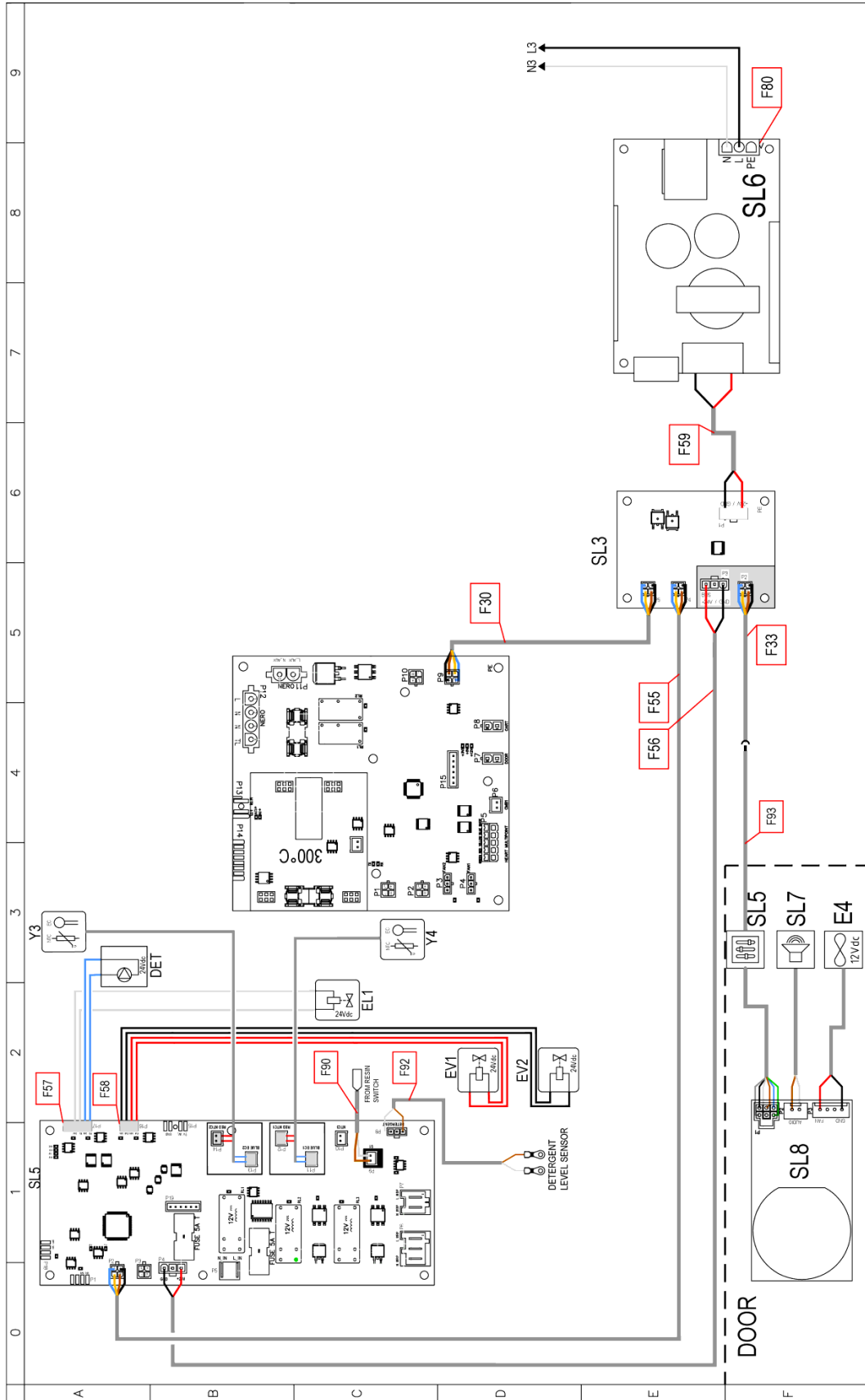

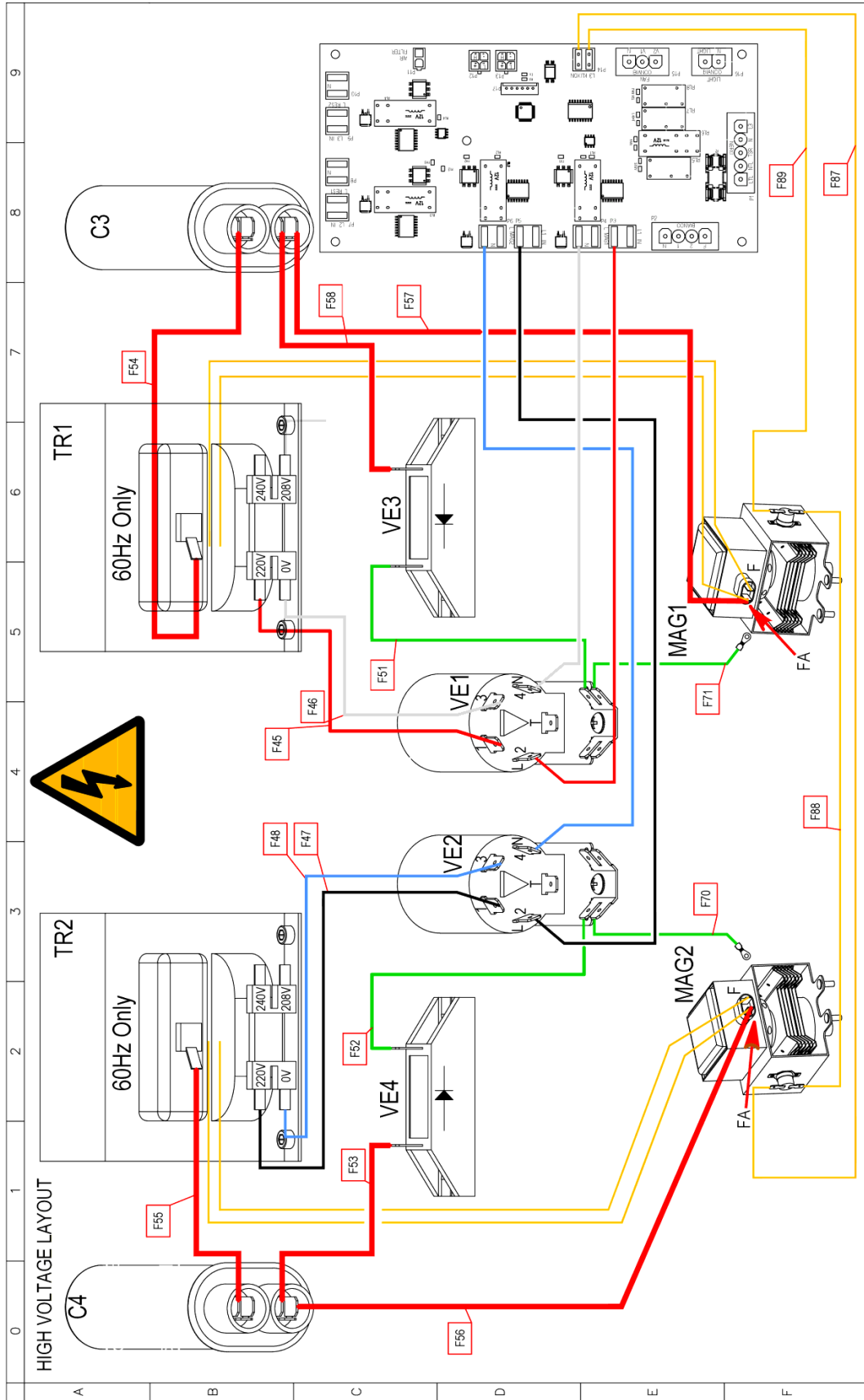

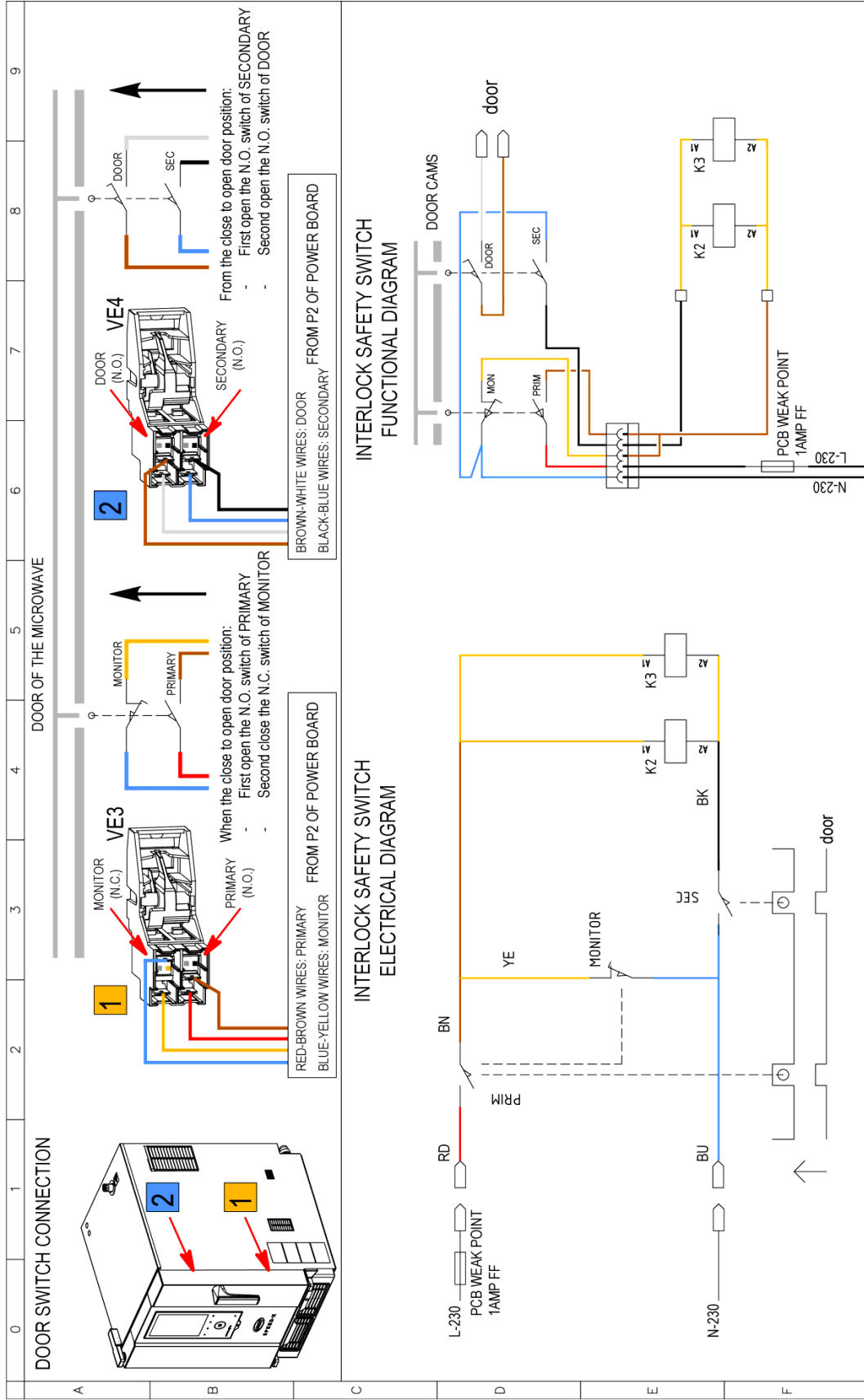

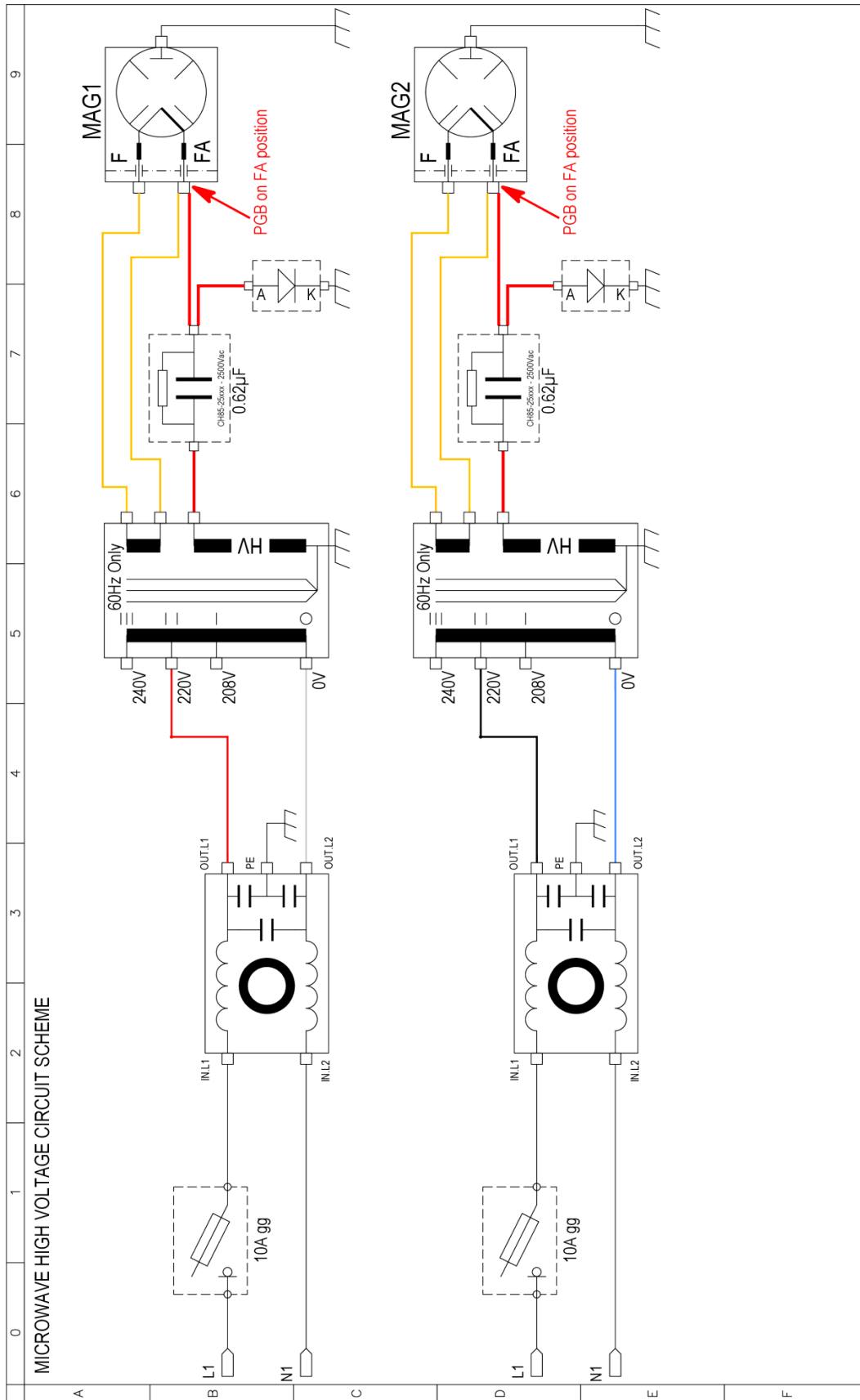



**ED1507A**

**POWER SUPPLY - CONNECTION DIAGRAM**

380-415V ~ 3PH + N + PE 60Hz

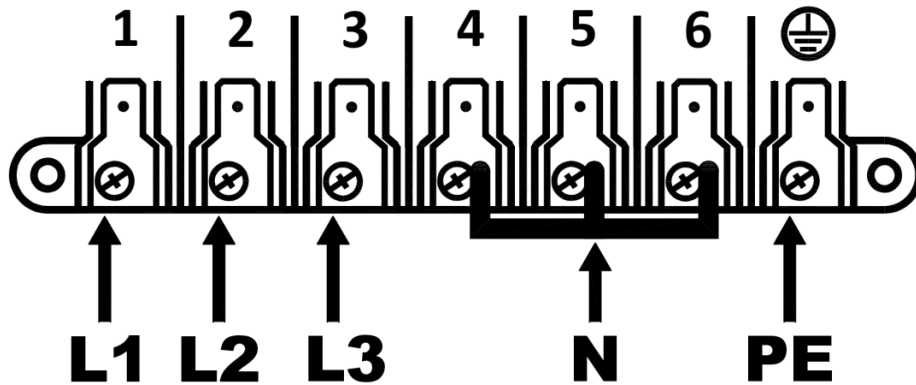

220-240V ~ 3PH + PE 60Hz

